

INSOL®

ARCHITECTURAL ALUMINIUM LOUVRES

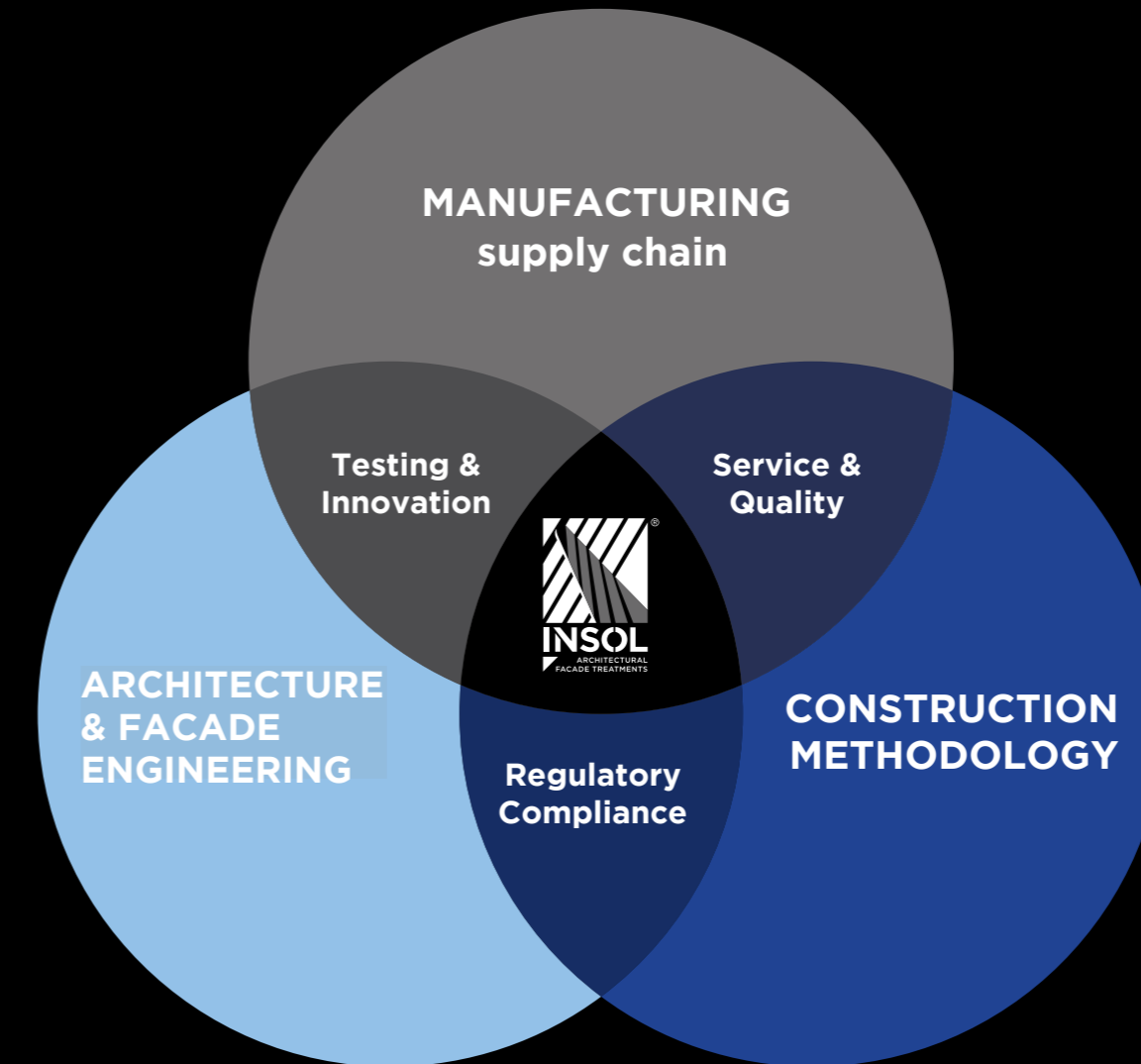

The right louvres enhance and define the character of a building. Then beyond the aesthetics, they deliver real benefits for solar control, screening and occupant comfort. Our systems are supported by design and testing capability that only Insol can offer.



It began back in the 1950's. That's when tools were picked up for the first time and the family involvement in the construction industry started.

In 2003 architectural louvre systems overseas started to change, becoming more intricate, more complicated and more beautiful. There was a vision of bringing these international design trends to New Zealand. To do this, Insol was born.

But it wasn't just a case of importing and installing. The vision always called for more. Those trends had to be adapted to suit the NZ market. To suit our tastes and our environment. Taking it further - what if we could design, manufacture and install everything ourselves? Rather than replicate trends - what if we could start them?

As Insol began to gain a reputation for innovation and bringing a solution focused approach to projects, the scope of work expanded and we became a full service provider of bespoke architectural facades enhancements.

Today, we are the only specialists in New Zealand who focus solely on bespoke architectural facades and screening. We're a team of designers, engineers and project managers. We're experts in turning architectural vision into reality.

We remain a family company.

THE INSOL WIND TUNNEL

With the ability to replicate real world conditions at 1:1 scale, the Wind Tunnel at the Insol Facade Testing Laboratory is unique in the Southern Hemisphere.

Wind Tunnel Testing

Louvre profiles, connection details and assemblies can be tested at full scale. Wind related issues such as wind noise and aero-elastic flutter can be ironed out in the process. Performance and behavior of dynamic elements such as sliding or bi-folding screens can be determined in a safe environment.

This testing is unique to Insol.



PROFILE DATA

AURORA™ Aerofoil Single Piece Louvre Blades

The AURORA™ louvre system is a comprehensive range of aerofoil louvres and accompanying bracketry designed with features that provide versatility, shading, screening, size options, and a unique architectural statement.

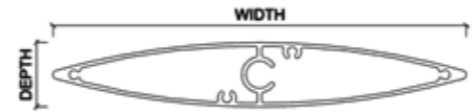

Product Number	Overall Dimensions Width x Depth	Weight kg/m
AU-LVR 90	90 mm x 12 mm	0.743
AU-LVR 110	110 mm x 18 mm	1.277
AU-LVR 120	120 mm x 12 mm	0.941
AU-LVR 150-25	150 mm x 25 mm	1.834
AU-LVR 150-35	150 mm x 35 mm	1.922
AU-LVR 180-F	180 mm x 30 mm	2.088
AU-LVR 180	180 mm x 30 mm	2.720
AU-LVR 190	190 mm x 30 mm	2.547
AU-LVR 200	200 mm x 33 mm	2.646

PROFILES

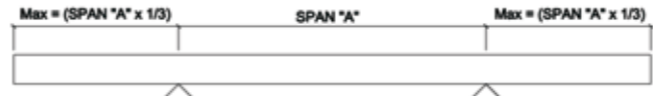

Wind Zone	Low	Medium	High	Very High
Wind Speed	32 m/s	33 to 37m/s	38 to 44 m/s	45 to 50 m/s
Factored Pressure	0.88 kPa	1.18 kPa	1.68 kPa	2.17 kPa
SPAN 'A' MAXIMUM	1.8m	1.6m	1.4m	1.2m
	2.6m	2.4m	2.2m	2.0m
	1.8m	1.6m	1.4m	1.2m
	3.4m	3.2m	2.8m	2.6m
	4.4m	4.0m	3.6m	3.2m
	4.0m	3.6m	3.2m	2.8m
	4.0m	3.6m	3.2m	3.0m
	3.8m	3.6m	3.2m	3.0m
	4.2m	3.8m	3.4m	3.0m

STANDARD MOUNT OPTIONS

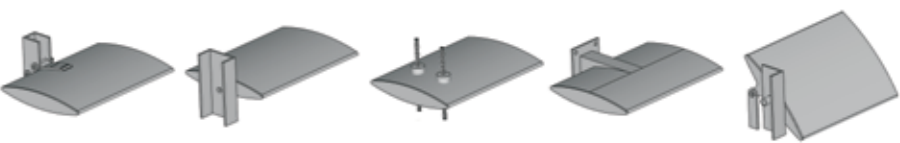

Mount Option	Clasp Bracket	End	Cable Suspended Mount	Spigot	Operable Mount
AU-LVR 90	—	—	—	—	—
AU-LVR 110	—	—	—	—	—
AU-LVR 120	—	—	—	—	—
AU-LVR 150-25	—	—	—	—	—
AU-LVR 150-35	—	—	—	—	—
AU-LVR 180-F	—	—	—	—	—
AU-LVR 180	—	—	—	—	—
AU-LVR 190	—	—	—	—	—
AU-LVR 200	—	—	—	—	—

— Denotes detail available for this profile.

PROFILE DATA

AURORA™ Aerofoil Multi Piece Louvre Blades

The AURORA™ aerofoil multi piece louvre blades provide a flexible system which can be scaled to suit design needs.

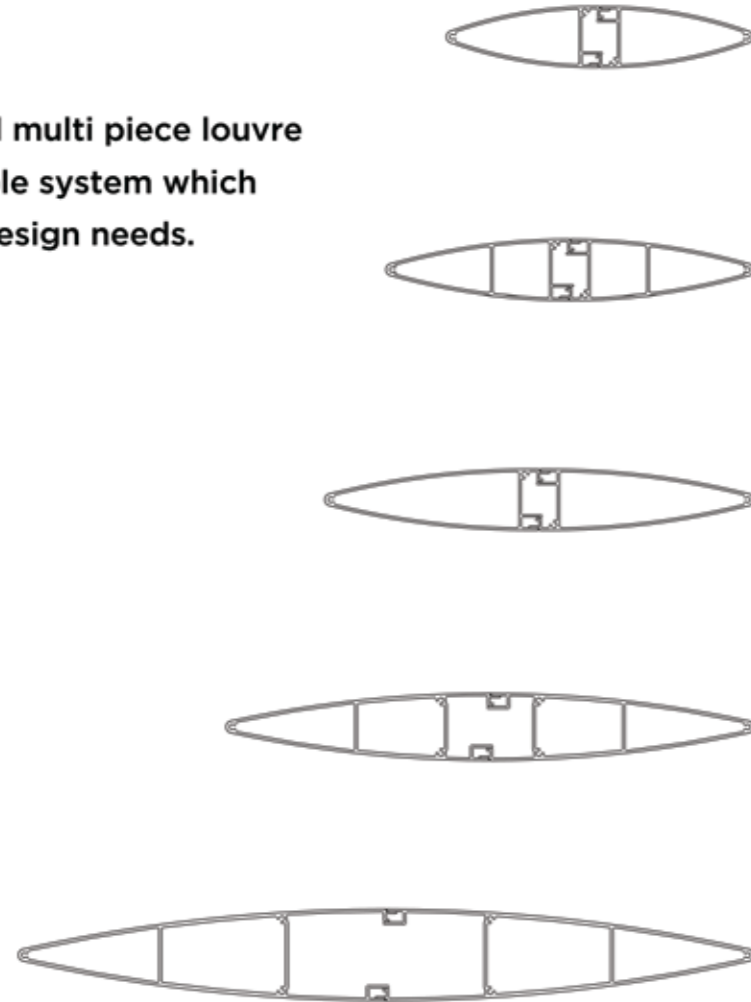

PROFILES

Product Number	Overall Dimensions Width x Depth	Weight kg/m
AU-LVR 250-CS	250 mm x 50 mm	3.734
AU-LVR 300-CS	300 mm x 50 mm	4.650
AU-LVR 350-CS	350 mm x 50 mm	4.806
AU-LVR 430-CS	430 mm x 55 mm	6.822
AU-LVR 600-CS	600 mm x 75 mm	10.008

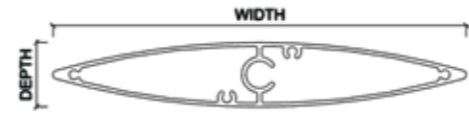

Wind Zone	Low	Medium	High	Very High
Wind Speed	32 m/s	33 to 37m/s	38 to 44 m/s	45 to 50 m/s
Factored Pressure	0.88 kPa	1.18 kPa	1.68 kPa	2.17 kPa

SPAN 'A' MAXIMUM	Low	Medium	High	Very High
	5.4m	4.8m	4.4m	3.8m
	5.4m	4.8m	4.4m	4.0m
	5.4m	4.8m	4.4m	4.0m
	6.0m	5.4m	4.8m	4.4m
	7.0m	6.4m	5.6m	5.2m



STANDARD MOUNT OPTIONS

	Clasp Bracket	End	Cable Suspended Mount	Spigot	Operable Mount
	—	—	—	—	—
	—	—	—	—	—
	—	—	—	—	—
	—	—	—	—	—
	—	—	—	—	—

— Denotes detail available for this profile.

PROFILE DATA

SOLARIS™ Single Piece Louvre Blades (Square End)

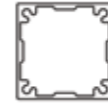

The SOLARIS™ louvre system is a range of rectangular louvre profiles that are available with a square or chamfered end.

The chunky rectangular profiles have a high visual impact and are popular in modern architecture.



PROFILES

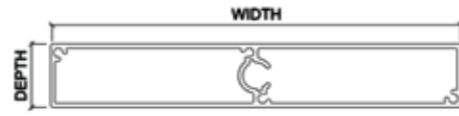

Product Number	Overall Dimensions Width x Depth	Weight kg/m
SLRS-LVR 50-S	50 mm x 50 mm	1.449
SLRS-LVR 100-S	100 mm x 50 mm	1.507
SLRS-LVR 125-S	125 mm x 50 mm	1.735
SLRS-LVR 150-S	150 mm x 50 mm	2.088
SLRS-LVR 200-S	200 mm x 50 mm	3.021
SLRS-LVR 300-S	300 mm x 50 mm	4.713

Wind Zone	SPAN 'A' MAXIMUM			
	Low	Medium	High	Very High
Wind Speed	32 m/s	33 to 37m/s	38 to 44 m/s	45 to 50 m/s
Factored Pressure	0.88 kPa	1.18 kPa	1.68 kPa	2.17 kPa
SPAN 'A' MAXIMUM	6.0m	5.6m	5.0m	4.6m



STANDARD MOUNT OPTIONS

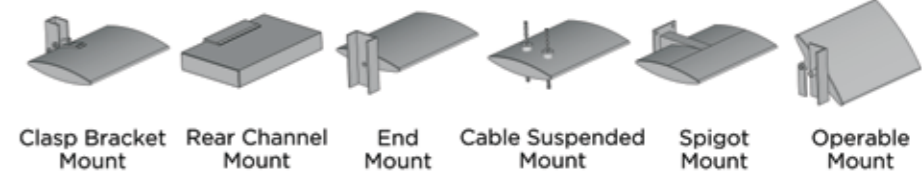

Clasp Bracket Mount	Rear Channel Mount	End Mount	Cable Suspended Mount	Spigot Mount	Operable Mount
		—	—		
—	—	—	—	—	—
—	—	—	—	—	—
—	—	—	—	—	—
—	—	—	—	—	—
—	—	—	—	—	—

— Denotes detail available for this profile.

PROFILE DATA

SOLARIS™ Single Piece Louvre Blades (Chamfered End)



The SOLARIS™ chamfered louvre profiles are designed to allow good operating clearances for motorised louvre systems.

They are also popular as fixed blades, providing the rectangular look with a slight difference.

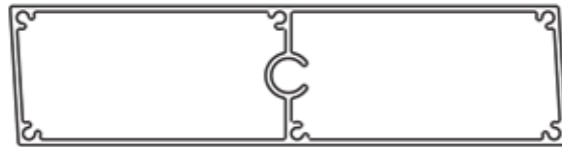

PROFILES

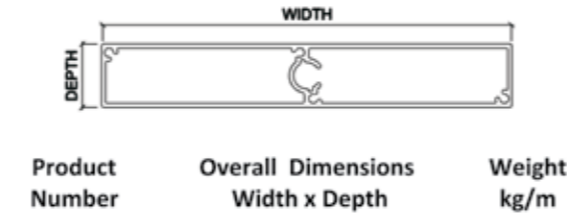

Product Number Overall Dimensions Width x Depth Weight kg/m

SLRS-LVR 110-CH 110 mm x 20 mm 1.452

SLRS-LVR 180-CH 180 mm x 30 mm 2.600

SLRS-LVR 200-CH 200 mm x 50 mm 3.226

SLRS-LVR 240-CH 240 mm x 50 mm 3.687

Wind Zone	SPAN 'A' MAXIMUM			
	Low	Medium	High	Very High
Wind Speed	32 m/s	33 to 37m/s	38 to 44 m/s	45 to 50 m/s
Factored Pressure	0.88 kPa	1.18 kPa	1.68 kPa	2.17 kPa



3.6m 3.2m 2.8m 2.6m

5.0m 4.6m 4.0m 3.6m

6.0m 5.6m 5.0m 4.6m

6.0m 5.6m 5.0m 4.6m

STANDARD MOUNT OPTIONS

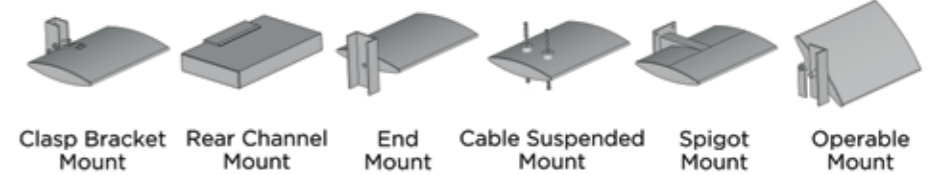

Clasp Bracket Mount	Rear Channel Mount	End Mount	Cable Suspended Mount	Spigot Mount	Operable Mount
—					
—	—	—	—	—	—
—	—	—	—	—	—
—	—	—	—	—	—

— Denotes detail available for this profile.

PROFILE DATA

SOLARIS™ Multi Piece 50mm Louvre Blades (Square End)



The **SOLARIS™ 50mm multi piece louvre blades provide a flexible system which can be scaled to suit design needs.**



PROFILES

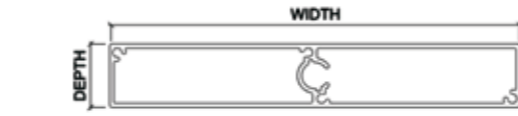

Product Number	Overall Dimensions Width x Depth	Weight kg/m
SLRS-LVR 250-CS/S	250 mm x 50 mm	5.154
SLRS-LVR 300-CS/S	300 mm x 50 mm	5.339
SLRS-LVR 350-CS/S	350 mm x 50 mm	6.644
SLRS-LVR 400-CS/S	400 mm x 50 mm	7.949
SLRS-LVR 450-CS/S	450 mm x 50 mm	8.134
SLRS-LVR 500-CS/S	500 mm x 50 mm	9.438
SLRS-LVR 600-CS/S	600 mm x 50 mm	10.928

Wind Zone Wind Speed Factored Pressure	SPAN 'A' MAXIMUM			
	Low 32 m/s 0.88 kPa	Medium 33 to 37m/s 1.18 kPa	High 38 to 44 m/s 1.68 kPa	Very High 45 to 50 m/s 2.17 kPa
	6.0m	5.6m	5.0m	4.6m
	6.0m	5.6m	5.0m	4.6m
	6.0m	5.6m	5.0m	4.6m
	6.0m	5.6m	5.0m	4.6m
	6.0m	5.6m	5.0m	4.6m
	6.0m	5.6m	5.0m	4.6m
	6.0m	5.6m	5.0m	4.6m



STANDARD MOUNT OPTIONS

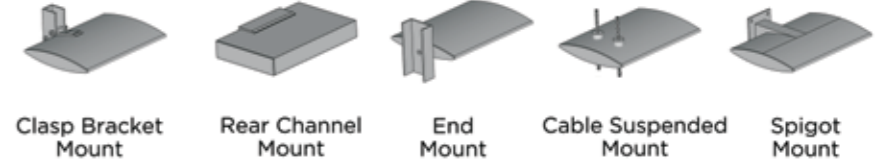

Clasp Bracket Mount	Rear Channel Mount	End Mount	Cable Suspended Mount	Spigot Mount
—	—	—	—	—
—	—	—	—	—
—	—	—	—	—
—	—	—	—	—
—	—	—	—	—
—	—	—	—	—
—	—	—	—	—

— Denotes detail available for this profile.

PROFILE DATA

SOLARIS™ Multi Piece Louvre Blades (Chamfered End)

The SOLARIS™ multi piece louvre profiles are also available with the chamfered design allowing for good operating clearances on motorised louvre systems.

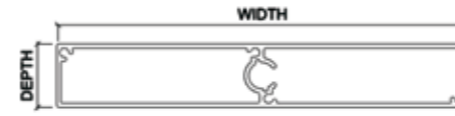

PROFILES

Product Number	Overall Dimensions Width x Depth	Weight kg/m
SLRS-LVR 150-CS/CH	150 mm x 50 mm	2.959
SLRS-LVR 180-CS/CH	180 mm x 50 mm	3.292
SLRS-LVR 220-CS/CH	220 mm x 50 mm	3.964
SLRS-LVR 250-CS/CH	250 mm x 50 mm	4.298
SLRS-LVR 300-CS/CH	300 mm x 50 mm	4.852
SLRS-LVR 450-CS/CH	450 mm x 50 mm	7.648
SLRS-LVR 600-CS/CH	600 mm x 50 mm	10.441

Wind Zone Wind Speed Factored Pressure	SPAN 'A' MAXIMUM			
	Low 32 m/s 0.88 kPa	Medium 33 to 37m/s 1.18 kPa	High 38 to 44 m/s 1.68 kPa	Very High 45 to 50 m/s 2.17 kPa
	6.0m	5.6m	4.8m	4.4m
	6.0m	5.6m	5.0m	4.6m
	6.0m	5.6m	5.0m	4.6m
	6.0m	5.6m	5.0m	4.6m
	6.0m	5.6m	5.0m	4.6m
	6.0m	5.6m	5.0m	4.6m

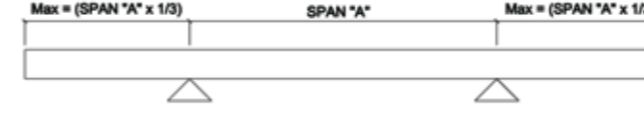

STANDARD MOUNT OPTIONS

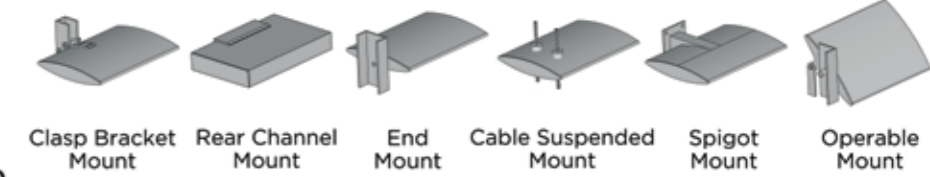

Clasp Bracket Mount	Rear Channel Mount	End Mount	Cable Suspended Mount	Spigot Mount	Operable Mount
—	—	—	—	—	—
—	—	—	—	—	—
—	—	—	—	—	—
—	—	—	—	—	—
—	—	—	—	—	—
—	—	—	—	—	—

— Denotes detail available for this profile.

PROFILE DATA

SOLARIS™ Multi Piece 75mm Louvre Blades (Square End)

The SOLARIS™ 75mm multi piece louvre blades provide the ultimate in flexibility, spanning capability and visual impact.

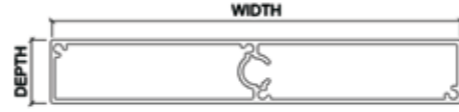

Product Number	Overall Dimensions Width x Depth	Weight kg/m
----------------	-------------------------------------	----------------

PROFILES

SLRS-LVR 240-75-CS	240 mm x 75 mm	6.415
SLRS-LVR 400-75-CS	400 mm x 75 mm	9.12
SLRS-LVR 600-75-CS	600 mm x 75 mm	13.873
SLRS-LVR 800-75-CS	800 mm x 75 mm	18.502
SLRS-LVR 1000-75-CS	1000 mm x 75 mm	23.146

Wind Zone	SPAN 'A' MAXIMUM			
	Low	Medium	High	Very High
Wind Speed	32 m/s	33 to 37m/s	38 to 44 m/s	45 to 50 m/s
Factored Pressure	0.88 kPa	1.18 kPa	1.68 kPa	2.17 kPa

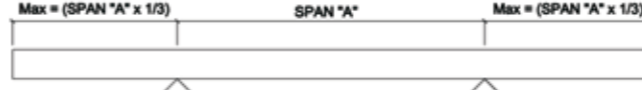

7.0m	7.0m	6.6m	5.8m
7.0m	7.0m	6.6m	5.8m
7.0m	7.0m	6.6m	5.8m
7.0m	7.0m	6.6m	5.8m

STANDARD MOUNT OPTIONS

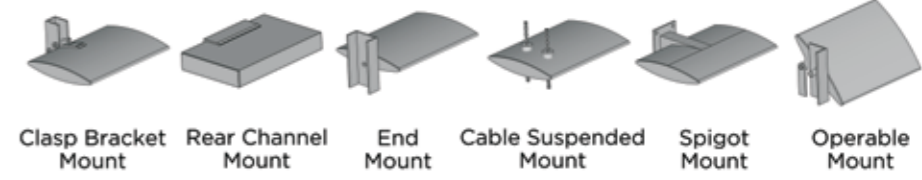

Clasp Bracket Mount	Rear Channel Mount	End Mount	Cable Suspended Mount	Spigot Mount	Operable Mount
—	—	—	—	—	—
—	—	—	—	—	—
—	—	—	—	—	—
—	—	—	—	—	—

— Denotes detail available for this profile.

PROFILE DATA

CALDERA™ Single & Multi Piece Parallelogram Louvre Blades

The CALDERA™ louvre system features a parallelogram shape. The sharp, distinct appearance of this system makes a striking complement to any modern architectural building and is rapidly becoming a very popular product.

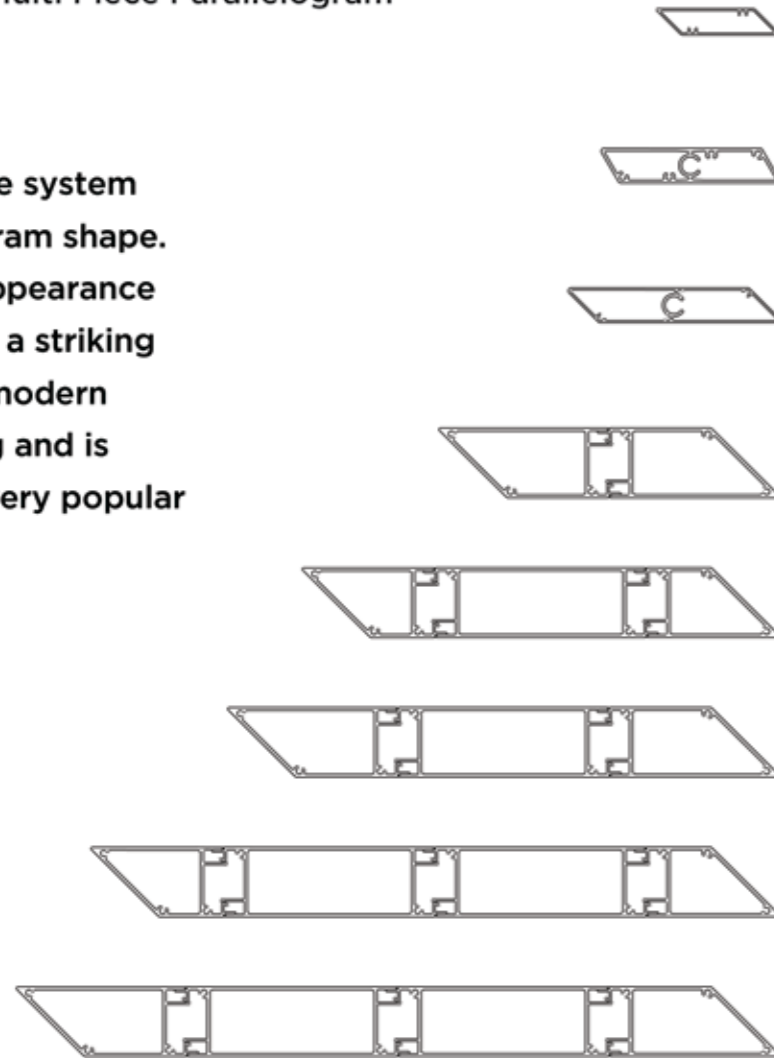

PROFILES

Product Number	Overall Dimensions Width x Depth	Weight kg/m
CLDR-LVR 88	88 mm x 19 mm	.800
CLDR-LVR 127	127 mm x 25 mm	1.991
CLDR-LVR 150	150 mm x 25 mm	1.628
CLDR-LVR 240-CS	240 mm x 50 mm	4.218
CLDR-LVR 340-CS	340 mm x 50 mm	6.308
CLDR-LVR 390-CS	390 mm x 50 mm	6.960
CLDR-LVR 490-CS	490 mm x 50 mm	9.053
CLDR-LVR 540-CS	540 mm x 50 mm	9.704

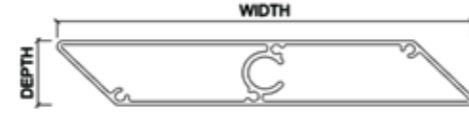

Wind Zone Wind Speed Factored Pressure	Low	Medium	High	Very High
	32 m/s 0.88 kPa	33 to 37m/s 1.18 kPa	38 to 44 m/s 1.68 kPa	45 to 50 m/s 2.17 kPa
SPAN 'A' MAXIMUM	3.0m	2.8m	2.4m	2.2m
	4.0m	3.6m	3.2m	3.0m
	3.8m	3.6m	3.2m	2.8m
	6.0m	5.4m	4.8m	4.4m
	6.0m	5.6m	4.8m	4.6m
	6.0m	5.4m	4.8m	4.4m
	6.0m	5.4m	4.8m	4.4m



STANDARD MOUNT OPTIONS

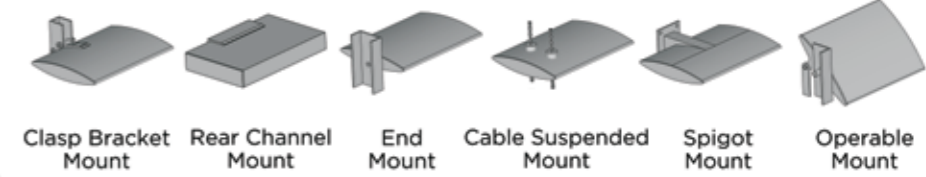

Clasp Bracket Mount	Rear Channel Mount	End Mount	Cable Suspended Mount	Spigot Mount	Operable Mount
—	—	—	—	—	—
—	—	—	—	—	—
—	—	—	—	—	—
—	—	—	—	—	—
—	—	—	—	—	—
—	—	—	—	—	—
—	—	—	—	—	—
—	—	—	—	—	—

— Denotes detail available for this profile.

PROFILE DATA

Custom Louvre Profiles



For the most distinct and unique aesthetics, custom louvre profiles can be designed and developed.

Custom louvre profiles and their fixing details are subject to the same stringent research and development protocols of the standard profiles. Comprehensive testing, which may include Wind Tunnel tests and analysis, offer the highest level of quality assurance.



PROFILES

Product Number	Overall Dimensions Width x Depth	Weight kg/m
SLRS-LVR 300-20-CS	300 mm x 20 mm	3.726
SLRS-LVR 450-20-CS	450 mm x 20 mm	5.656
SLRS-LVR 600-20-CS	600 mm x 20 mm	7.586
ROLST-LVR 200	200 mm x 30 mm	2.425
ROLST-LVR 160	160 mm x 20 mm	1.911
ZN-MV-LVR	73 mm x 11 mm	0.459
ZN-LVR 55	70 mm x 25 mm	0.470
ZN-LVR 70	140 mm x 62 mm	1.100

PROFILE DATA

Custom Louvre Profiles

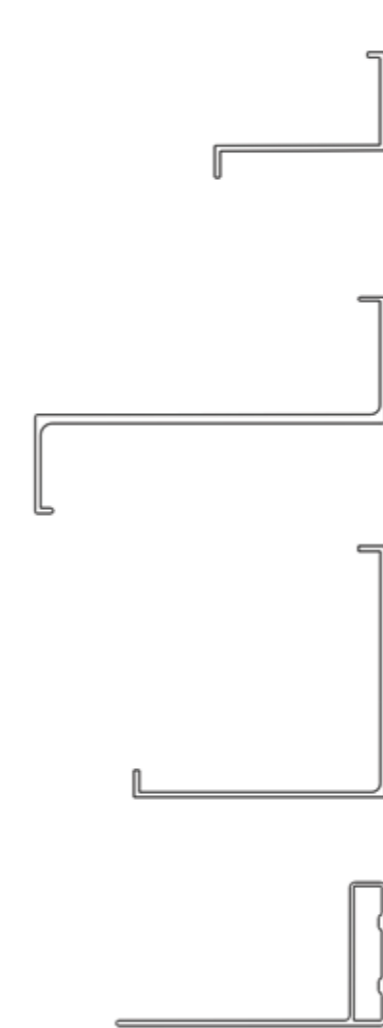

PROFILES

Product Number	Overall Dimensions Width x Depth	Weight kg/m
OSTN-LVR 95-70	95 mm x 70 mm	1.394
OSTN-LVR 195-120	195 mm x 120 mm	3.737
KEDW-LVR 140	140 mm x 140 mm	2.348
HRTN-LVR 150-80	150 mm x 80 mm	2.2852

PROJECT SPECIFIC ENGINEERED SOLUTIONS

Propriety Product

Most projects require some form of custom designed support structure to connect the louvre system to the building.

Building regulating authorities normally ask that custom designed support structures are signed off by a registered engineer with a producer statement (PS1).

The engineered solution provided by Insol can vary from large and complex structures to simple brackets.

Our solutions are supported with in-house capabilities.

- Design
- Drawing
- Engineering
- Wind tunnel testing

We can offer Early Contractor Involvement (ECI) on large or complex projects. Providing assurance that the louvre systems are properly designed and integrated.

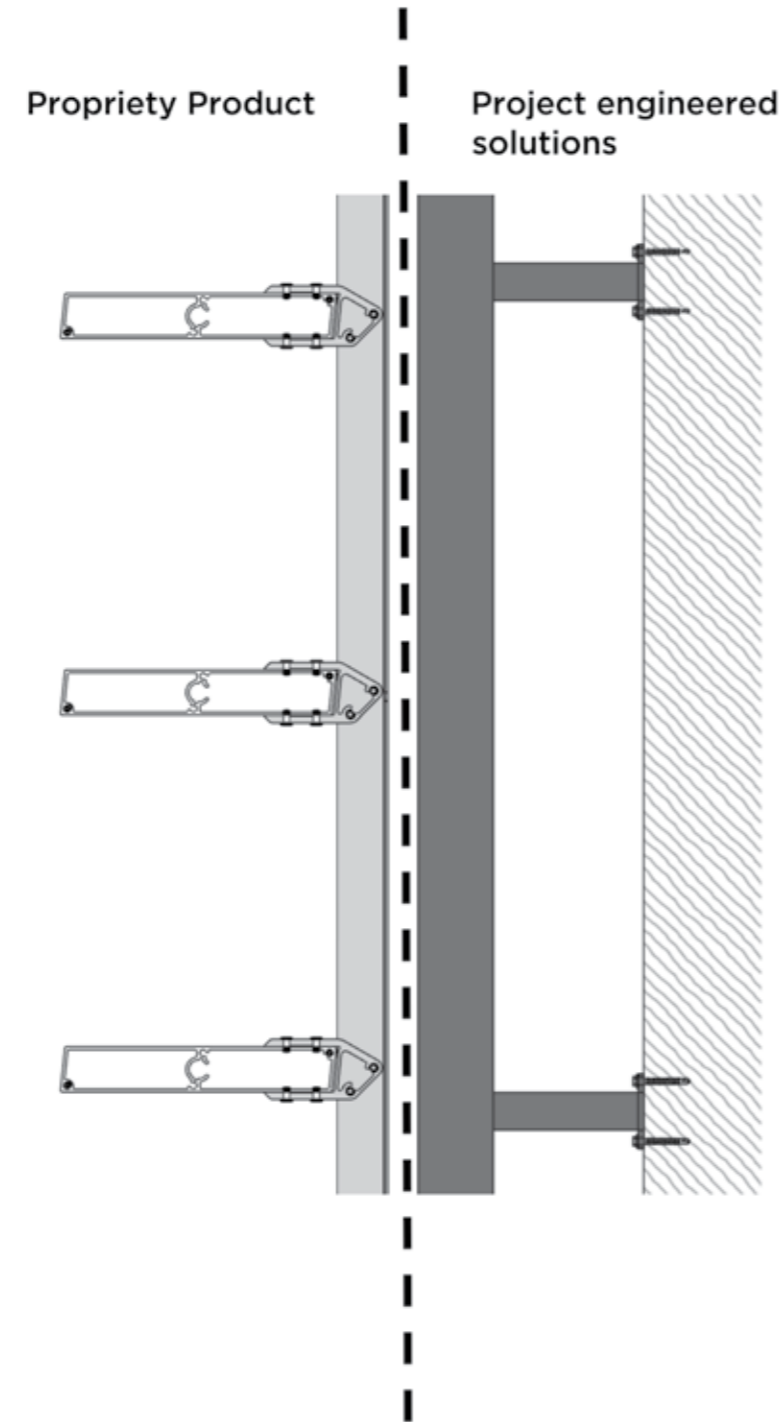

Standard Mounting Details

Clasp Bracket Mounting

Clasp bracket fixing allows multiple louvres to be installed along horizontal or vertical support lines. Louvres can be conveniently pitched and set in vertical or horizontal orientation.

Configuration and Layout:

- Vertical or Horizontal orientation.
- The louvre blades can be set at any centres.
- Blade angle is allowed to 45° either side of the support structure surface (non adjustable once fixed).

Assembly and Installation:

- Continuous clasp channels are fixed to primary or secondary support structure.
- The louvre blades are fixed to the clasp channel via clasp brackets with stainless fixings.

Structural Requirements:

The fixing detail of the clasp channel back to the main support structure varies dependent on the type of structure and wind loadings on the louvre. Contact Insol for project specific recommendations.

Componentry and Finishes:

- Extruded profiles and components are grade 6060 T5 aluminium suitable for powder-coat or anodised finish.
- All fixings are 316 stainless steel.

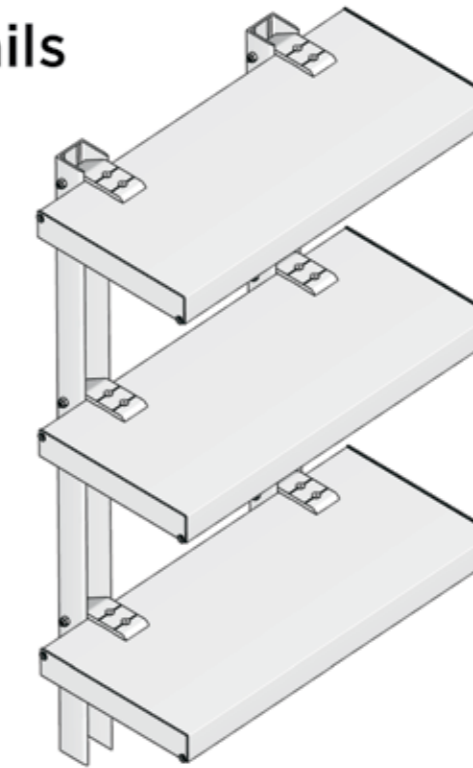

Pictorial View

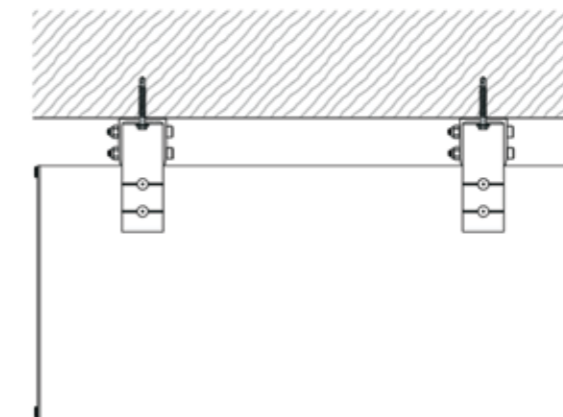

Plan View

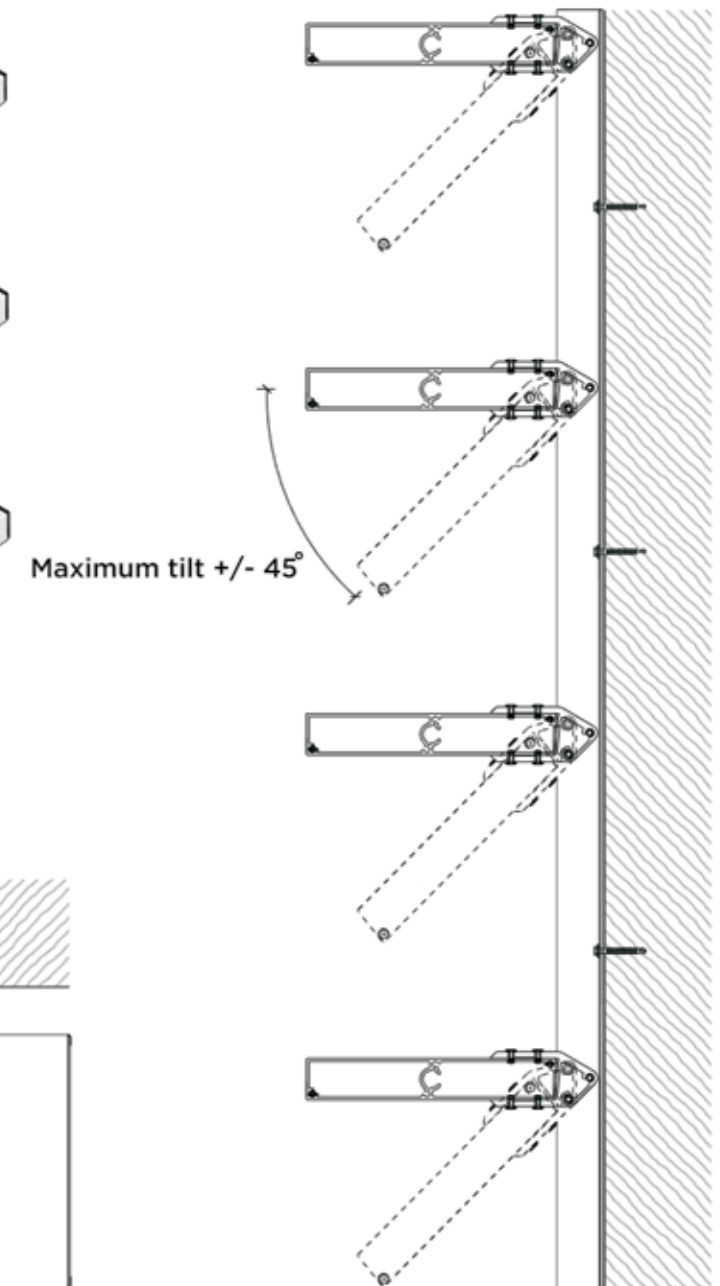

Sectional View

Standard Mounting Details

Rear Channel Mounting

Rear channel mount fixing allows individual louvres to be installed along varying horizontal or vertical support lines. Louvres can be set perpendicular to the support face in a vertical or horizontal orientation.

Configuration and Layout:

- Vertical or Horizontal orientation.
- The louvre blades can be set at any centres.
- Blade angle is restricted to 90° from the support structure surface.

Assembly and Installation:

- Continuous or sectional rear mount channels are fixed to primary or secondary support structure.
- The louvre blades are inserted into the channel and fixed off using stainless steel rivets or machine screws.

Structural Requirements:

The fixing detail of the rear mount channel back to the main support structure varies dependent on the type of structure and wind loadings on the louvre. Contact Insol for project specific recommendations.

Componentry and Finishes:

- Extruded profiles and components are grade 6060 T5 aluminium suitable for powder-coat or anodised finish.
- All fixings are 316 stainless steel.

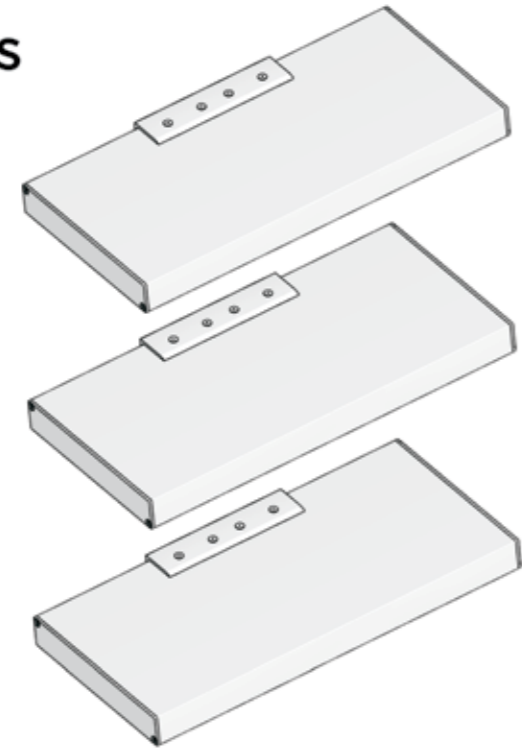

Pictorial View

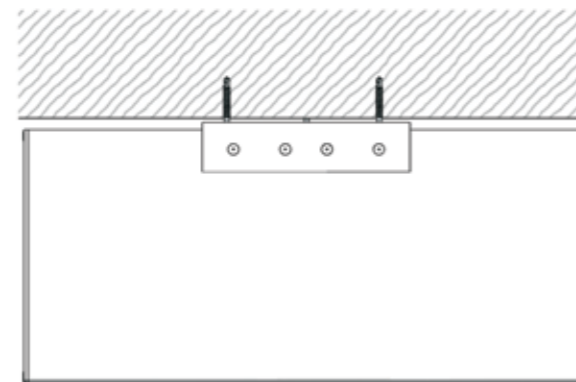

Plan View

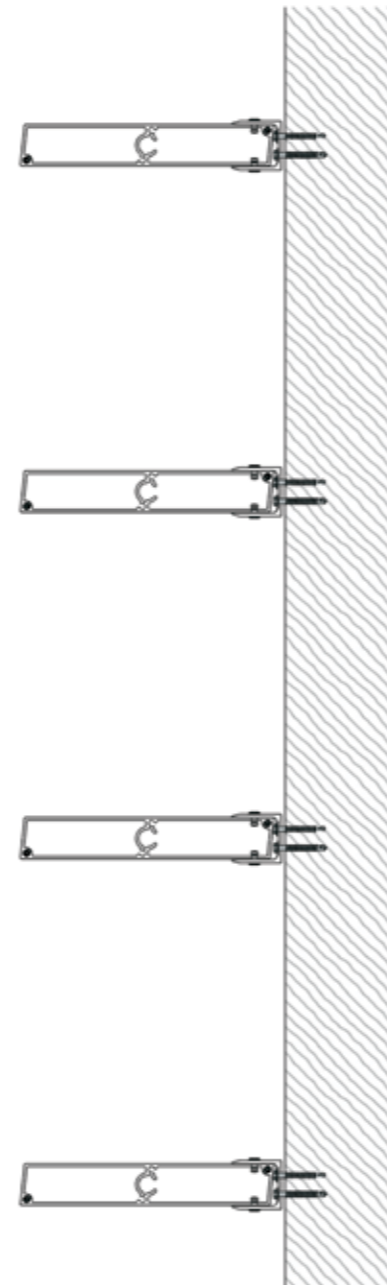

Sectional View

Standard Mounting Details

End Fix Mounting

End fixing allows multiple louvres to be installed between horizontal or vertical support lines. Louvres can be pitched and set at varying angles and centres in a vertical or horizontal orientation.

This fixing method is particularly suited to situations where louvres are being installed between “wing-walls” or within “day-light openings”.

Configuration and Layout:

- Vertical or Horizontal orientation.
- The louvre blades can be set at any centres.
- Blade angle is not restricted and can be pitched at any angle (non adjustable once fixed).

Assembly and Installation:

- Continuous support rails are fixed to primary or secondary support structure.
- The louvre blades and end fixing channels are assembled into panels which are then inserted between support rails and fixed off using stainless steel rivets or machine screws.

Structural Requirements:

The end fixing to support rail detail back to the main support structure varies dependent on the type of structure and wind loadings on the louvre. Contact Insol for project specific recommendations.

Componentry and Finishes:

- Extruded profiles and components are grade 6060 T5 aluminium suitable for powder-coat or anodised finish.
- All fixings are 316 stainless steel.

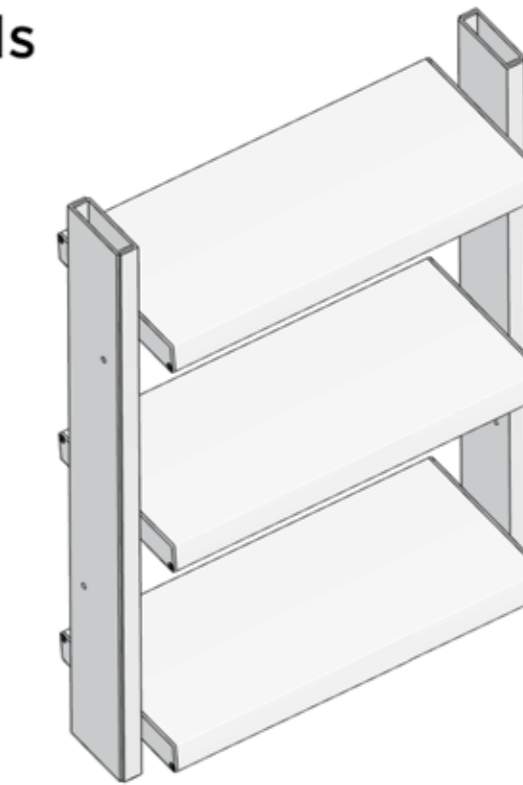

Pictorial View



Plan View

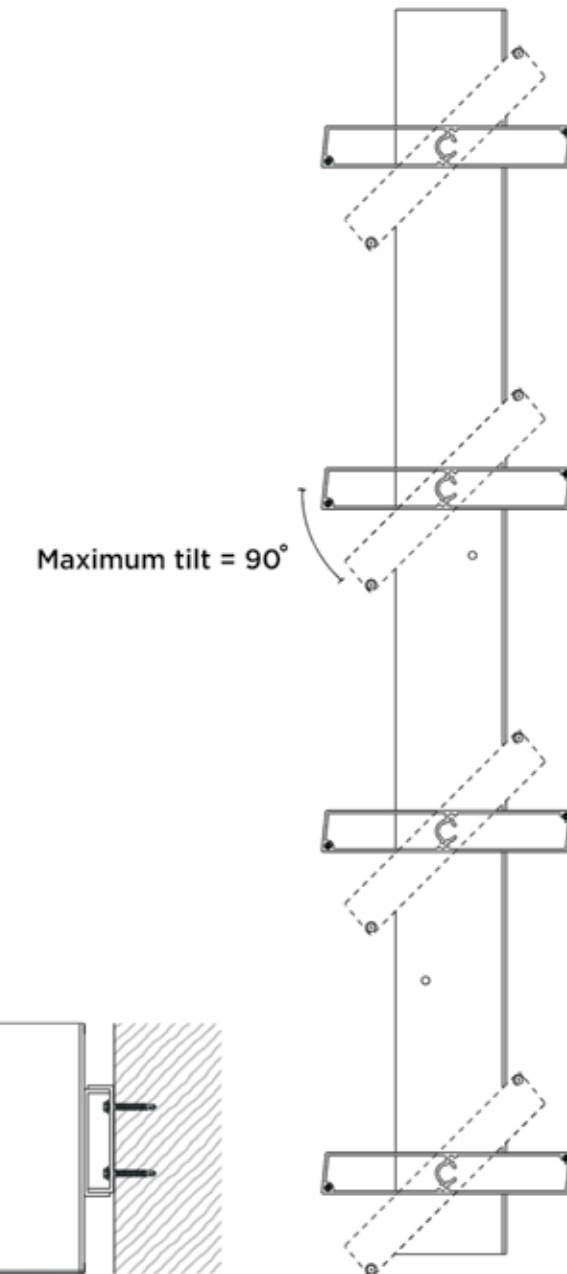

Sectional View

Maximum tilt = 90°

Standard Mounting Details

Operable Mounting

Operable mounting allows multiple louvres to be installed along horizontal or vertical support lines. Louvres can be set in a vertical or horizontal orientation at uniform centres, with an adjustable angle of pitch. This fixing method is particularly suited to situations where adjustable shading is required. Louvre movement can be manually or electrically operated.

Configuration and Layout:

- Vertical or Horizontal orientation.
- The louvre blades to be set at uniform centres only.
- Blade angle is fully operable and adjustable through 110°.

Assembly and Installation:

- Continuous machined support rails are fixed to primary or secondary support structure.
- The louvre blades are assembled to the support rails via spring loaded axles and coupled with a continuous "link bar".

Structural Requirements:

The fixing details of the operable mount back to the main support structure varies dependent on the type of structure and wind loadings on the louvre. However typically the support rails would be set within a "day-light opening" or at the head and sill of a window opening.

Componentry and Finishes:

- Extruded profiles and components are grade 6060 T5 aluminium suitable for powder-coat or anodised finish.
- All fixings are 316 stainless steel.

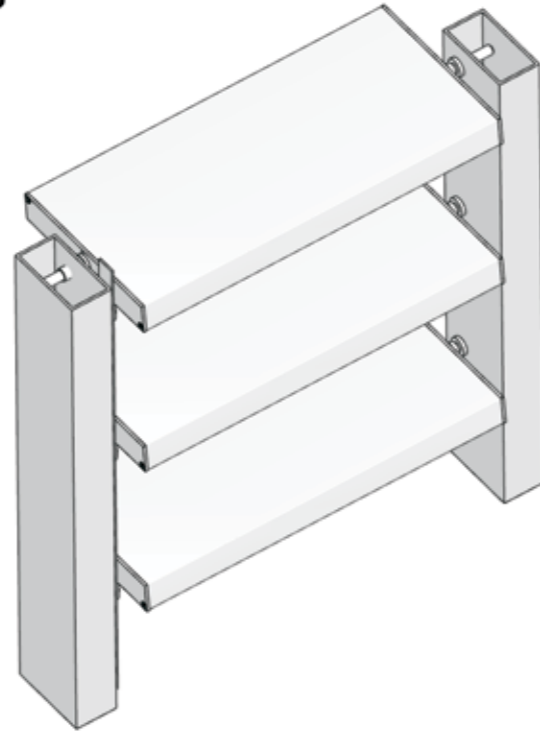

Pictorial View



Plan View

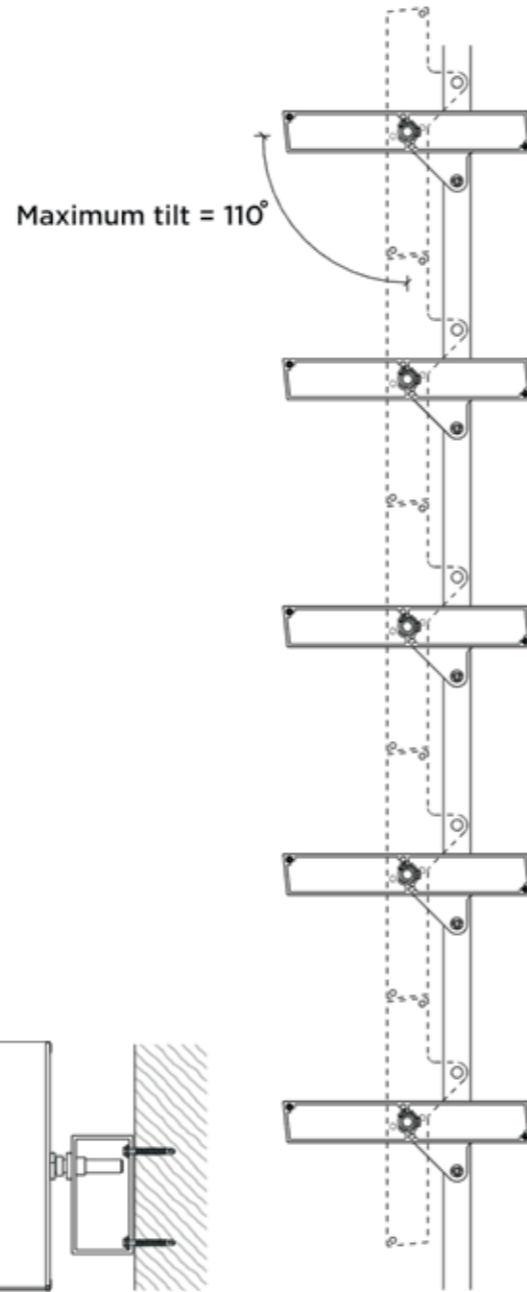

Sectional View

Standard Mounting Details

Suspension Cable Mounting

Cable mounting allows multiple louvres to be installed between horizontal support lines. Louvres can be pitched and set at varying angles and centres in a horizontal orientation. This fixing method is particularly suited to situations where a "minimal mid-panel" support structure is desired.

Configuration and Layout:

- Horizontal orientation only.
- The louvre blades can be set at any centres.
- Blade angle is restricted to 15° either side of perpendicular to the support cables (non adjustable once fixed).

Assembly and Installation:

- Connection rails or tabs are fixed to primary or secondary support structure at head and sill.
- The louvre blades and cables are pre-assembled into "drops" which are then fixed between connection points and tensioned via turn-buckles.

Structural Requirements:

The fixing detail of the connection rails or tabs back to the main support structure varies dependent on the type of structure and wind loadings on the louvre. However, typically the structure will need to with-stand considerable tensional loading from the cables. Contact Insol for project specific recommendations.

Componentry and Finishes:

- Extruded profiles and components are grade 6060 T5 aluminium suitable for powder-coat or anodised finish.
- All fixings are 316 stainless steel.

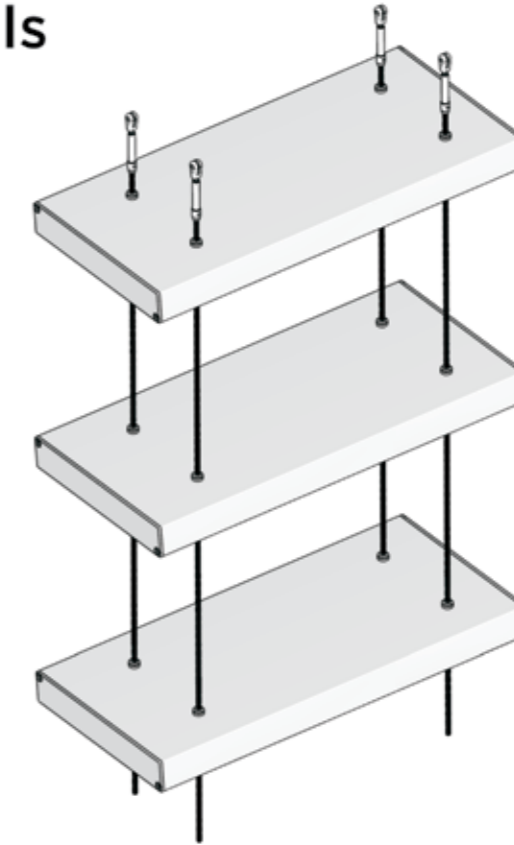

Pictorial View



Plan View

Maximum tilt = 15°

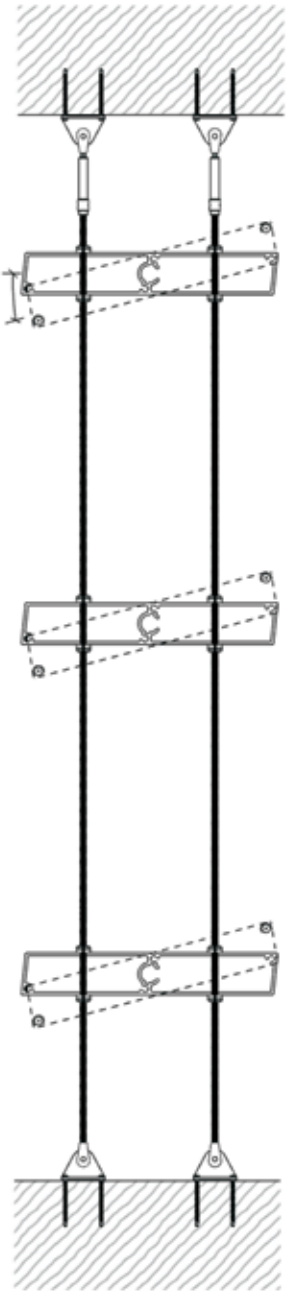

Sectional View

Standard Mounting Details

Spigot Mounting

Spigot mounting allows individual louvres to be installed along varying horizontal or vertical support lines. Louvres can be set perpendicular to the support face in a vertical or horizontal orientation. This fixing method is particularly suited to situations where Louvres are widely spaced or the visual effect of support rails is to be avoided.

Configuration and Layout:

- Vertical or Horizontal orientation.
- The louvre blades can be set at any centres.
- Blade angle is restricted to 90° from the secondary support structure surface.

Assembly and Installation:

- Flanged Spigots are fixed to the face of the primary or secondary support structure.
- The louvre blades are slid onto spigots and fixed off using stainless steel rivets or machine screws.

Structural Requirements:

The fixing details of the spigot mount back to the main support structure varies dependent on the type of structure and wind loadings on the louvre. However, typically the fixings would be along a floor or spandrel line.

Componentry and Finishes:

- Extruded profiles and components are grade 6060 T5 aluminium suitable for powder-coat or anodised finish.
- All fixings are 316 stainless steel.

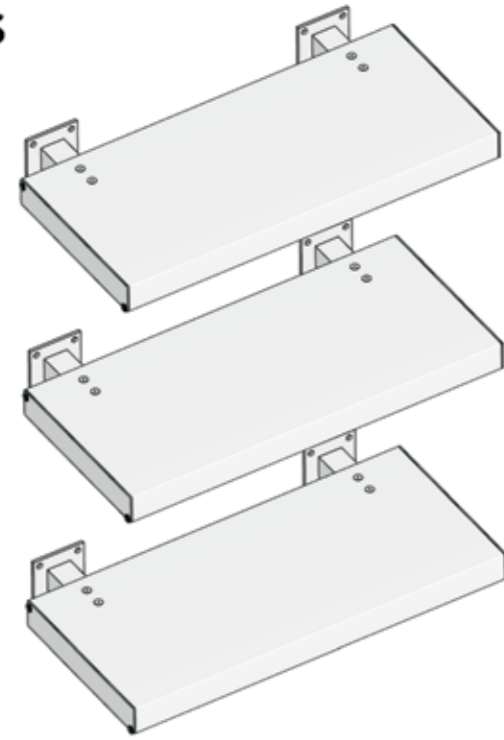

Pictorial View

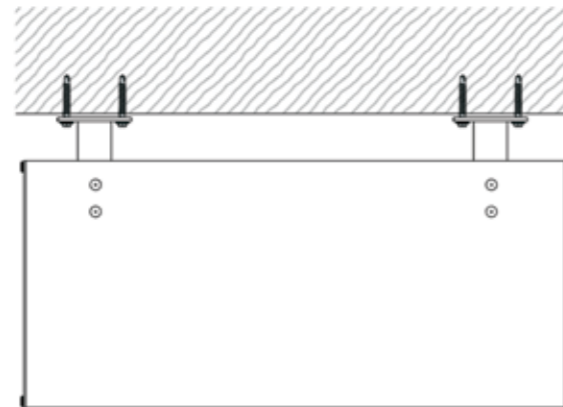

Plan View

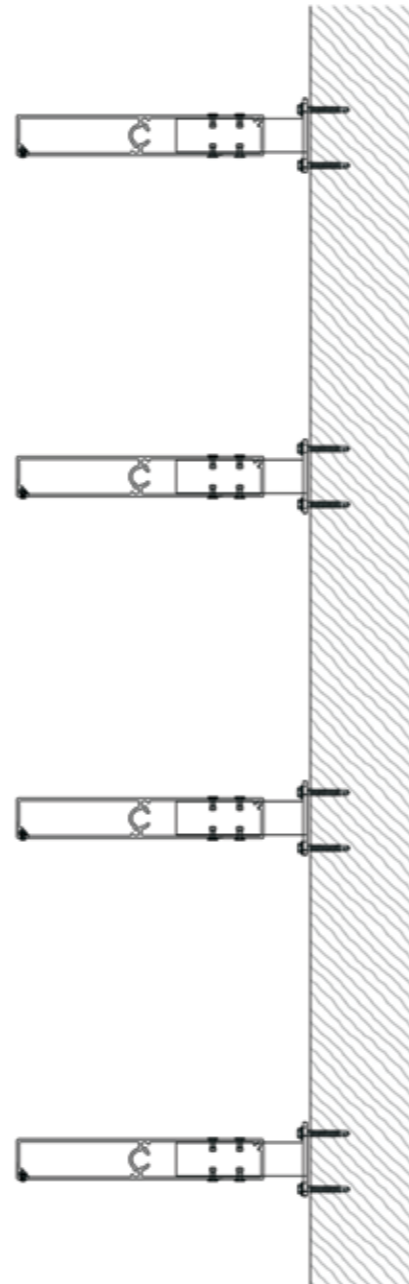

Sectional View

Standard Mounting Details

Profiled End Mounting

Profiled end mounting allows multiple louvres to be installed to horizontal or vertical support lines. Louvres can be pitched and set at varying angles and centres in a vertical or horizontal orientation. This fixing method is particularly suited to situations where louvres are being installed to the face of a structure as pre-assembled "Louvred Panels".

Configuration and Layout:

- Vertical or Horizontal orientation.
- The louvre blades can be set at any centres.
- Blade angle is not restricted and can be pitched at any angle (non adjustable once fixed).

Assembly and Installation:

- Louvres are pre-assembled to end rails then the complete assembly is fixed to face of primary or support structure.

Structural Requirements:

The fixing details for the profiled end mount back to the main support structure varies dependent on the type of structure and wind loadings on the louvre.

Componentry and Finishes:

- Extruded profiles and components are grade 6060 T5 aluminium suitable for powder-coat or anodised finish.
- All fixings are 316 stainless steel.

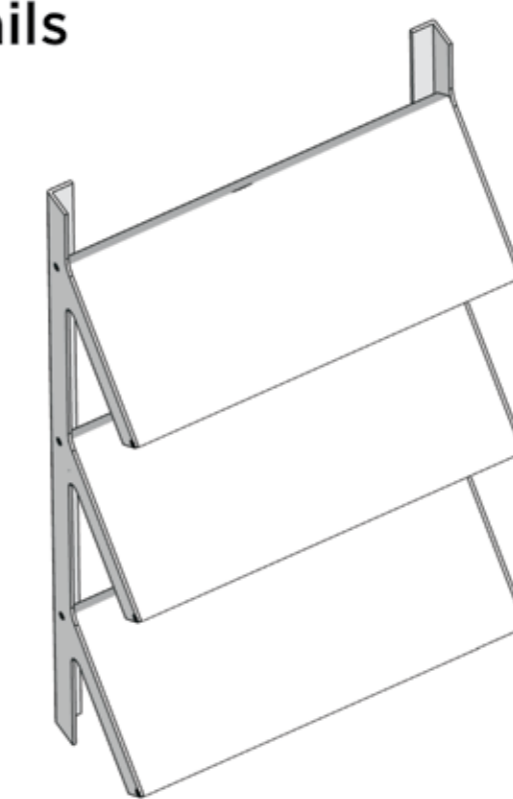

Pictorial View



Plan View

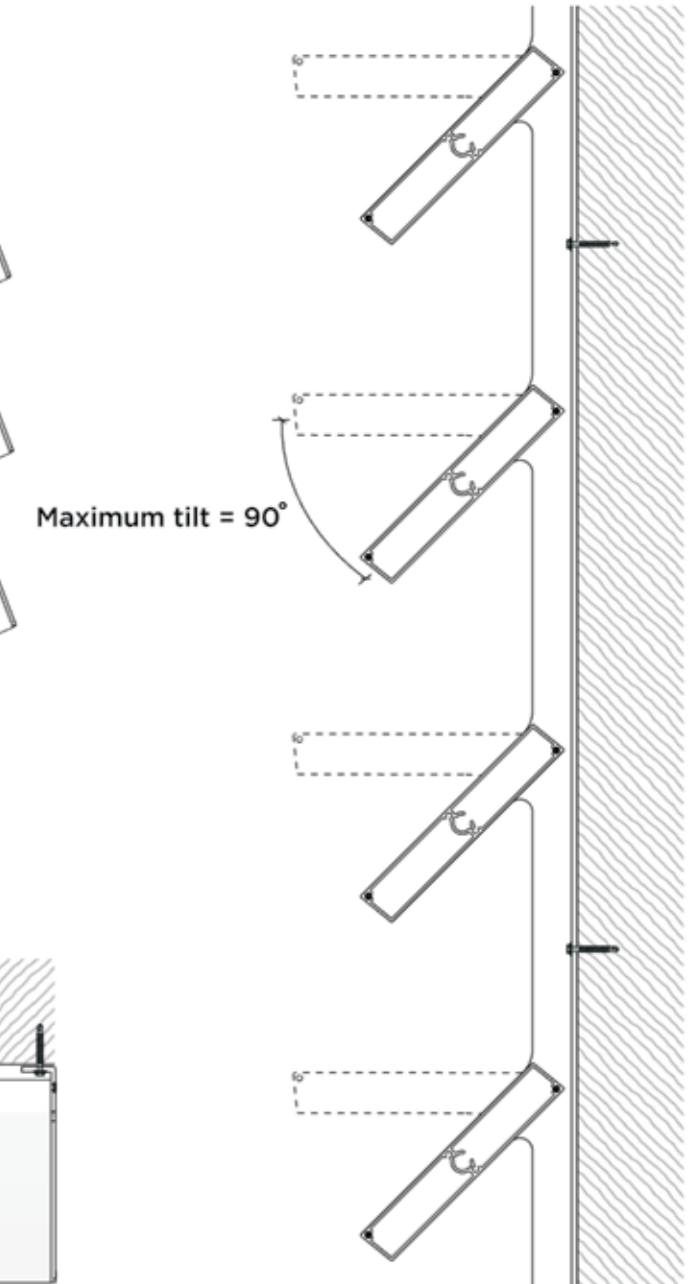

Sectional View

GISBORNE DISTRICT COUNCIL ADMINISTRATION BUILDING

Project Credits
Client: Gisborne District Council
Location: Gisborne
Architect: Chow Hill Architects Ltd
Builder: Watts and Hughes Construction

A building designed to reflect and represent the dual reality of the people, their history and the diversity in the community in the Tairāwhiti Region. The exterior takes its curved appearance from the waka and ships that sailed to the region, creating a lasting connection to place, people and the past.

Louvre blades were affixed via an adjustable mechanism. This allowed each individual blade to be manipulated to the perfect angle. The connection to the building was rolled to achieve

that subtle (and specific) curve, a specialist task only undertaken by a small number of experts in New Zealand.

The building was awarded the 2019 Gisborne/Hawkes Bay NZIA Local Architecture Award for Commercial Architecture.

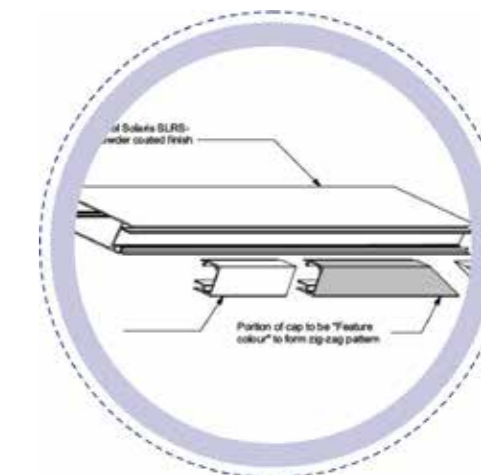

CREST APARTMENTS

Project Credits

Client: Maidstone Properties

Location: Grey Lynn, Auckland

Architect: Paul Brown & Associates

Contractor: Ganelen Construction

From their elevated position atop a ridge, the Crest Apartments and accompanying two storey villas are able to simultaneously stand above, yet blend into, the mixed residential zone of the surrounding neighborhood.

Louvre spacing is repeated on every second level, with continuing intermittent design lines. A rear mount channel was used for fixing the louvres into place, achieving the clean and clear look required from the design.

The result is a building that straddles two worlds, inhabiting both with an aesthetic that seamlessly transitions the gaze from one environment to another. The distinct building forms cleverly address the issues of their surroundings, the result being a beauty that blends but also strikes its own identity.

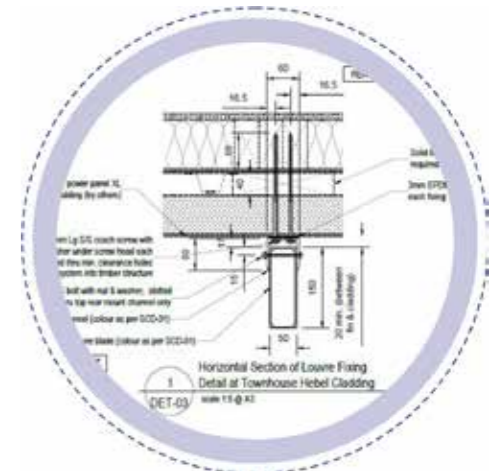

OUTLOOK APARTMENTS

Project Credits

Client: 263 Kepa Road Limited

Location: Kepa Road, Auckland

Architect: MAP Architects

Contractor: Clearwater Construction



The Kepa Road facade features a veil of anodised aluminium tubes, hinting at movement and playfully following you as you move past with a shimmering reflection from the sun.

One of the main features is a screen of vertical 38mm diameter aluminium tubes that wrapped around the corners of the building. Computer analysis of the airflows around this feature determined that physical testing was necessary to eliminate the risk.

We then carried out physical 1:1 scale testing which confirmed we could proceed with the architectural detail and maintain the intent. The finished apartments shine with a unique facade that adds a rich warmth to the exterior. The light reflection on the facade seemingly dances as you move past, playfully setting the building apart whilst maintaining a high level of distinction.

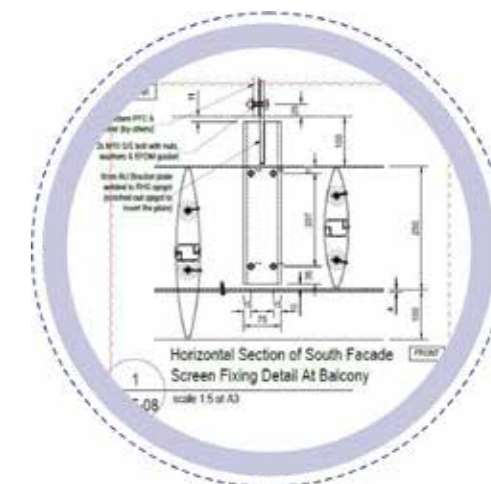

ST MARKS APARTMENTS

Project Credits

Client: St Marks

Location: Auckland

Architect: Patterson Associates, Peddle Thorp

Contractor: Dominion Constructors



St Marks is a unique urban development, wonderfully accentuated by and taking breath from the integrated plants and greenery. Designed to be one of Auckland's finest residential buildings, the finishing and detail needed to be of the highest quality.

Aesthetically, the anodising colours of the louvres had to be exact, having been carefully selected to compliment the natural shades provided by the vertical greenery up the side of the building.

We worked closely with the architect to create bespoke detailing for the concealed fixing. This collaborative approach and attention to detail, whilst likely unnoticed by occupants, is something we enjoy for the satisfaction it provides both ourselves and the architect.

In 2019, St. Marks was recognised at the Property Council Awards where it was awarded Best in Category for the Housing New Zealand Multi-Unit Residential Property Award.

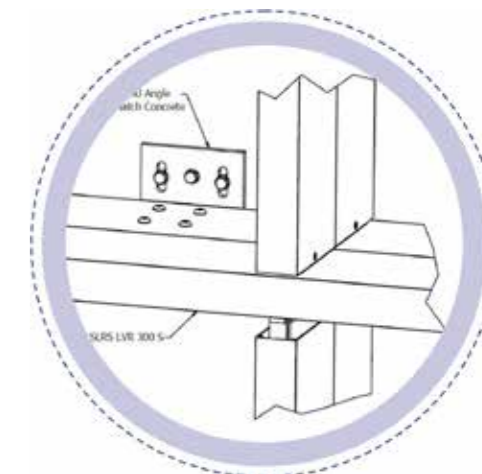

HIGHBROOK CAR PARK

Project Credits

Client: Goodman

Location: Auckland

Architect: JWA Architects Ltd

Contractor: SMC Construction



A wonderful design with an appeal which will grow over the years as the appearance alters, creeping greenery taking over the corner of the building. It's clever balance between the man-made and natural adds oxygen and freshness to functional purpose and needs.

Large 300 x 100 louvre fins were to be used for aesthetics, installed from a datum line, to help meet the correct position (5° angle from the vertical) and tolerances.

Any issues associated with the sub-structure tolerances were neutralised through a creative installation process, so the final lines matched the architectural intent. Custom machined hardware was developed for the wire cabling system, which will be so critical over the years as the creeping plants take hold.

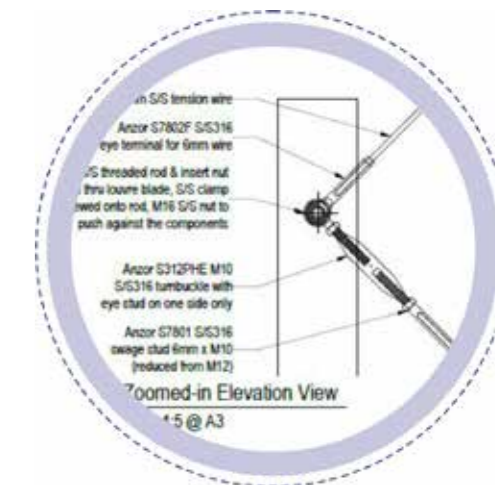

THE HILLS LODGE

Project Credits

Location: Lodge at The Hills / Arrowtown, NZ

Architect: Anna-Marie Chin, Crosson Clarke

Carnachan Chin Architects

Builder: RBJ Ltd Builders



The Hills Lodge is a standalone multimedia room. Fully integrated with the lodge building management system, the whole facade transforms via touch screen control. This metamorphosis is compelling to watch and offers occupants a number of easily controlled variations to suit their mood. From music which can escape and float away into the alpine air and offer views over Lake Hayes, to total darkness for motion picture immersion, it is a perfect place for relaxation and enjoyment.

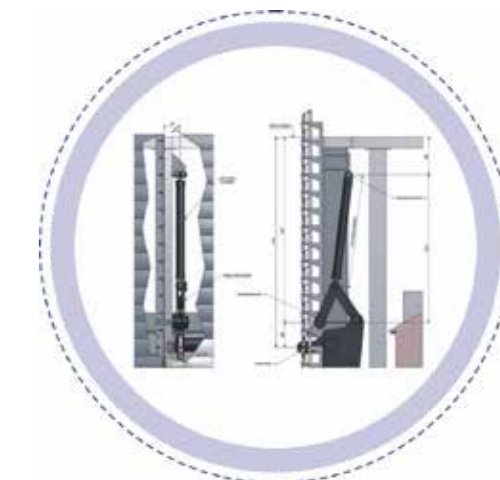

BURWOOD HOSPITAL

Project Credits

Location: Burwood Hospital / Christchurch

Architect: Sheppard & Rout, Jasmax, Klein

Builder: Leighs Cockram joint venture



The architect's vision called for significant solar control to meet the crucial comfort requirements of the occupants. Oversized vertical sunfins were to be used to create a striking visual identity, the bespoke facade striking a wonderful balance between functional effectiveness and aesthetic pleasure.

During the initial stages of the tender process, we identified a number of value engineering opportunities.

We proposed an offsite construction methodology and developed bespoke lifting equipment for the installation. This attention to detail and unique approach to installation methodology provided significant gain in speed, safety and budget, ultimately saving the client \$1million in cost. The completed project was to use over 60 tons of aluminium in bringing the architectural intent to life. Burwood Hospital is a project where the beauty is found not just in the finished product but also the creative solution used to achieve it.

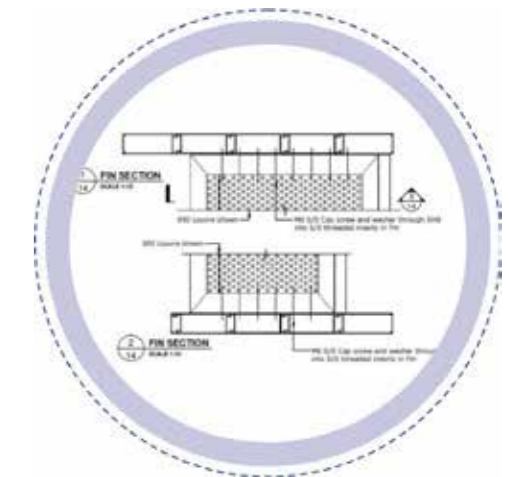

CLYDE QUAY WHARF

Project Credits

Client: Willis Bond

Location: Wellington Harbour

Architect: Athfield Architects

Builder: LT McGuiness



Five different louvre systems were used to provide occupants with privacy whilst creating the unique look of the building, accentuating and defining the ship aesthetic with the 'prow' and 'hull'. The result is a remarkable building which was awarded the overall NZ Architecture Award in 2015.

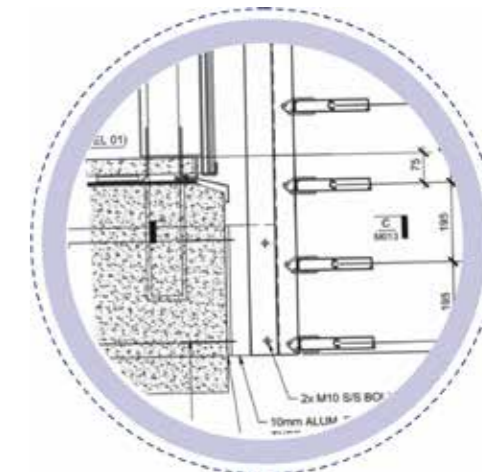

WEST END CAR PARK

Project Credits

Location: Christchurch

Client: Ngai Tahu Property

Architect: Warren & Mahoney

Builder: Southbase Construction

WEST END P



Engaged by the architects to provide a full design-build service of the louvered facade, different shades of bronze anodising form a rhythmic colour pattern over the facade. We developed a custom extruded blade profile and secondary aluminium support structure, then deployed a concealed bracketry system for a clean and appealing finish.

The result is a striking aesthetic which includes high performance double-bank ventilation louvres glazed into the window joinery frames.

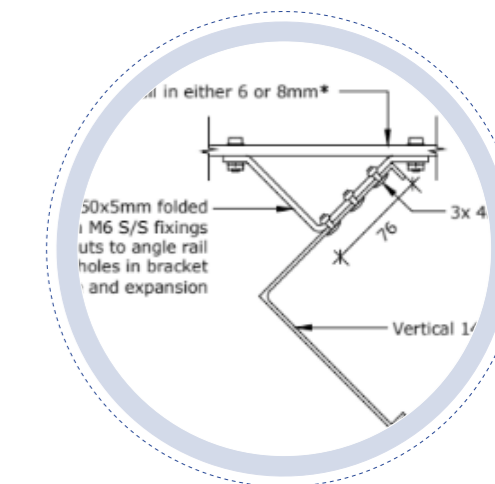

SYLVIA PARK OFFICE BUILDING

Project Credits

Client: Kiwi Property

Location: Mount Wellington, Auckland

Architect: Architectus Auckland

Builder: Dominion Constructors

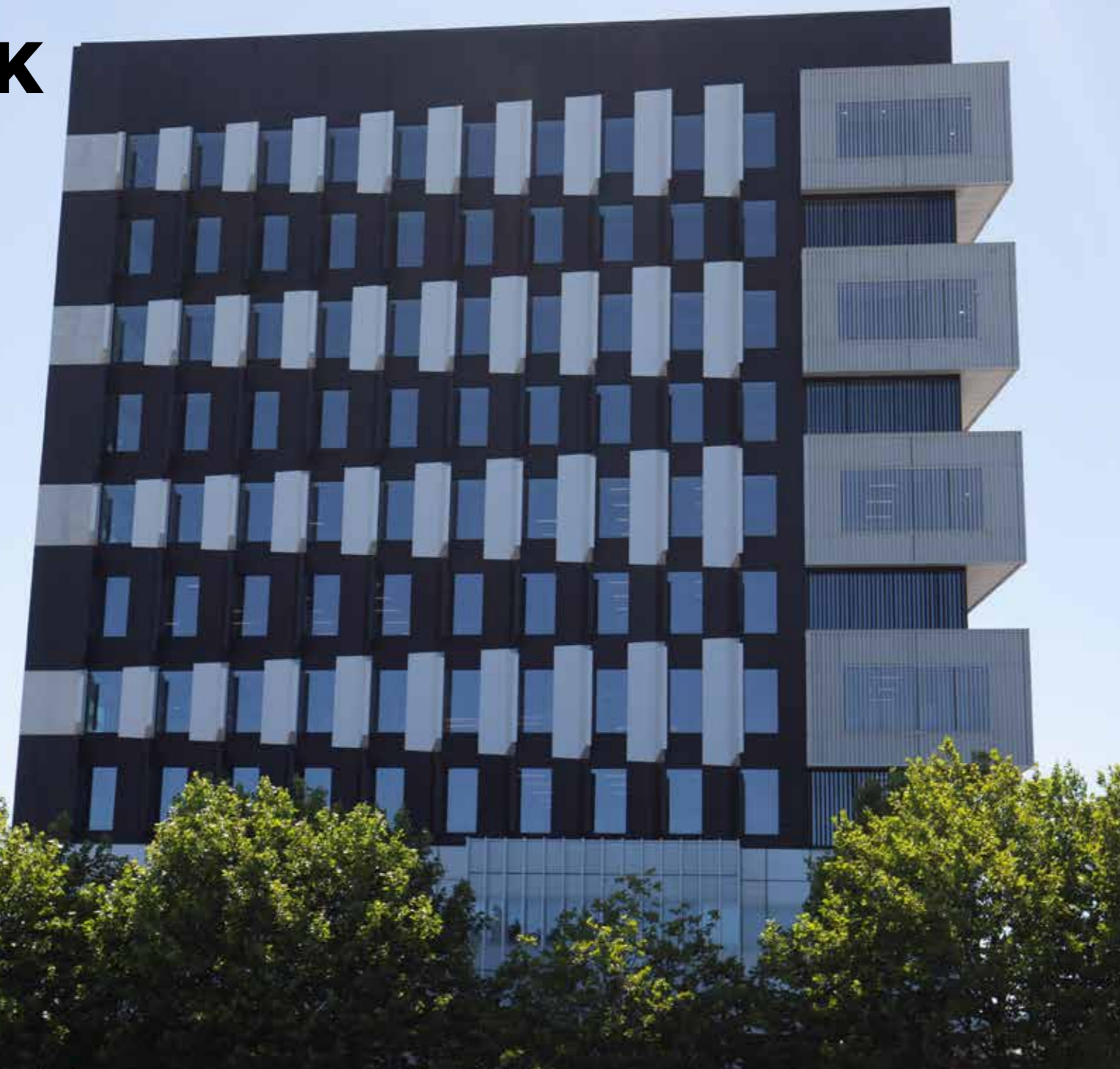

We developed a cost-effective bespoke solution that delivered the functionality and architectural intent, all within the constraints of the design-build model and existing budget.

The result is a visually striking architecture that helps shape the journey down to South Auckland.

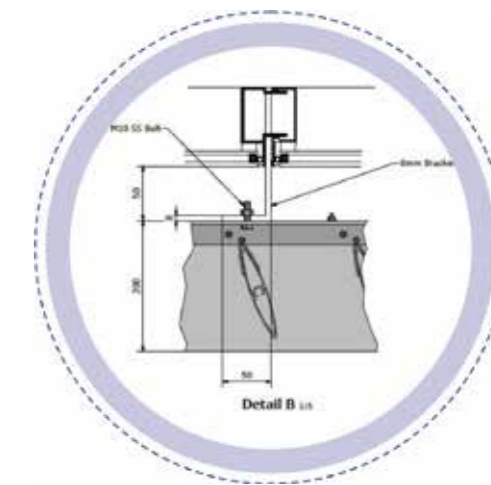

VODAFONE NZ HEADQUARTERS

Project Credits

Location: Takapuna, Auckland

Architect: Warren & Mahoney

Builder: NZ Strong Construction



An extensive refurbishment to the Vodafone headquarters used a 21 metre wide aluminium structure and vertical 450mm fins, spanning 5 storeys. The early morning sunstrike was reduced through the positioning of vertical fins. Then as the sun moves during the course of the day, horizontal perforated walkways come to the fore, defending occupants against late morning glare. Together, the functional effect met the requirements for occupant comfort, whilst aesthetically the character of the building was enhanced and modernised.

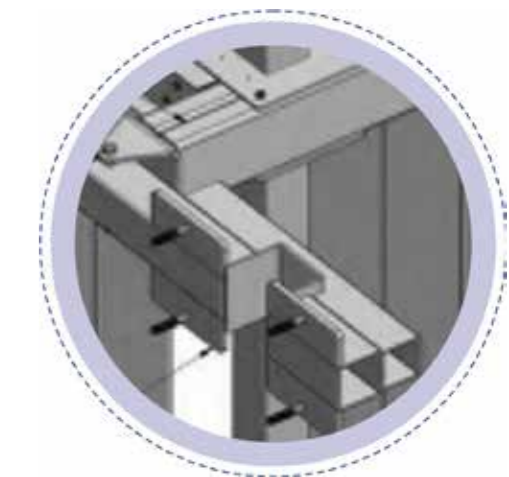

SERVICES WE PROVIDE

Design

We specialise in design solutions for complex projects with demanding architectural detail and construction methodology. Our combination of experience and expertise in design, engineering, manufacturing and construction management makes us uniquely placed to bring visions to fruition.

Design & engineering services are supported by advanced computer modelling and physical tests.

Solutions

We're active solution experts. That means we focus on an issue long enough to understand it - then we get to work on the solution. This is central to the Insol culture and the difference we bring. Working with architects on their vision, builders on their building methodology, or adjusting designs to meet budget...is all completed with the considered efficiency you'd expect from the experts.



7 Waokauri Place
Mangere, Auckland 2022
Ph: 09 276 9735



34 Onslow Street
Newfield, Invercargill 9812
Ph: 03 216 3287



www.linkedin.com/company/insol-ltd



www.instagram.com/insolnz



enquiries@insol.co.nz

www.insolarchitectural.com

